

SYSTEM 2™

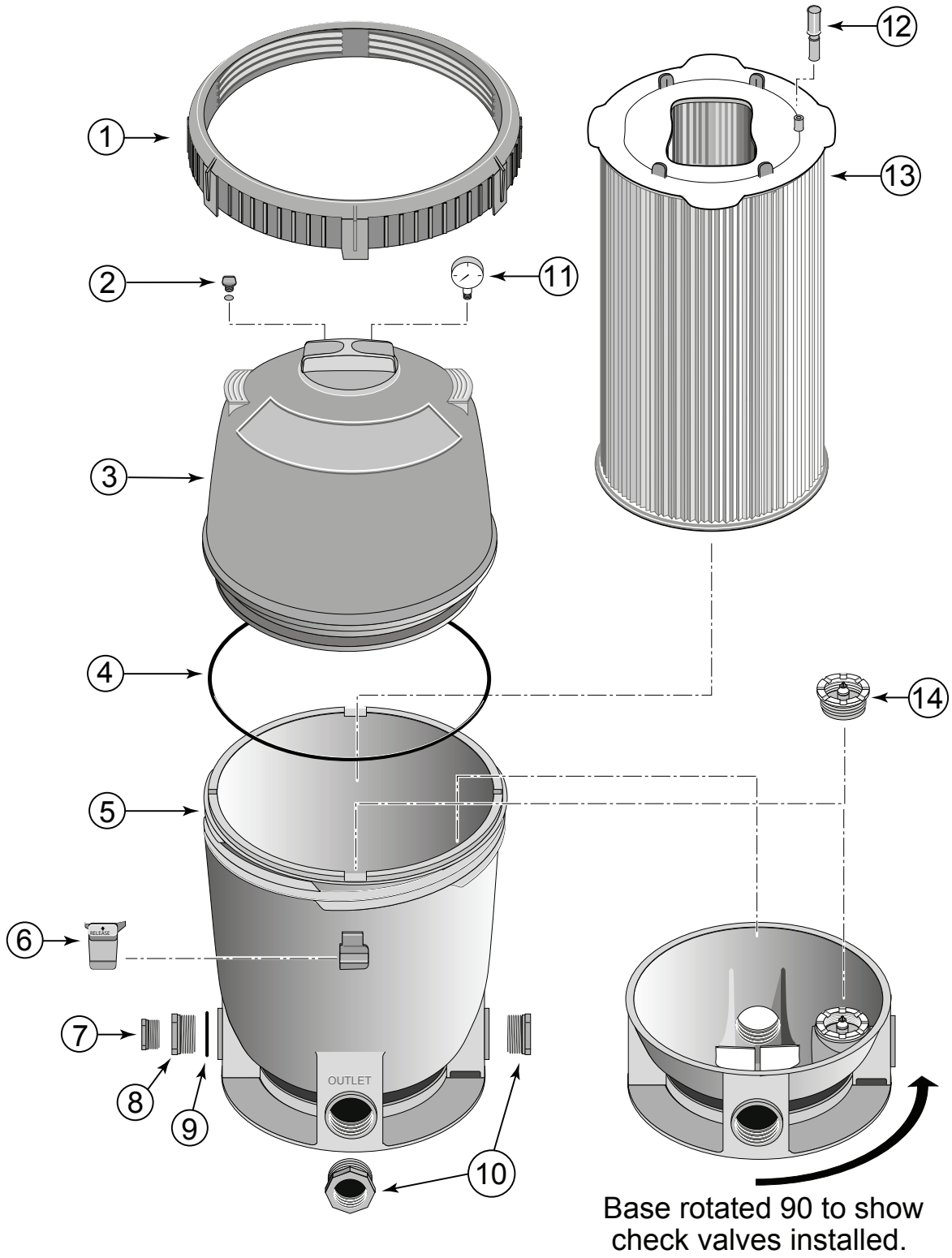

Base rotated 90 to show check valves installed.

SYSTEM 2™

Replacement Parts

No.	Part No.	Description	Part No. Includes
1	27001-0054	Posi-Lok™ Ring	1
2	25010-0200	Air release Valve Assembly	1
3	27001-0020S	Lid	1
4	27001-0061S	O-Ring	1
5	27001-0009S	Bottom Tank (includes Partn° 1, 6 & 8)	1
6	27001-0051	Safety Latch	1
7	27001-0022	Drain Plug	1
8	24900-0510	Drain Fitting	1
9	35505-1424	O-Ring	1
10	R960025	Union 2" NPT -> 50mm and 63mm	2
11	R152047	Manometer - Pressure Gauge (bottom connection)	1
12	24800-0121	Air Bleed Assembly	1
13	27002-0100S	Cartridge - Model PLM100	1
	27002-0150S	Cartridge - Model PLM150	1
	27002-0175S	Cartridge - Model PLM175	1
	27002-0200S	Cartridge - Model PLM200	1
14	27001-0130S	Spring check Valve*	1

* OPTIONAL EQUIPMENT

Rev. 08/2016

AUTOMATION

FILTERS

FILTER SYSTEMS

PUMPS

HEAT PUMPS

CLEANERS

WATER FEATURES

LIGHTS

SALT CHLORINATORS

DOSING & MEASURING

SANITIZERS

WHITE GOODS

MAINTENANCE ACCESSORIES

OTHER